



CEETUS ENTERPRISE CORPORATION

希得股份有限公司

# DC DRIVER BUCKXX-DM SERIES

High Power Constant Current LED Driver Dimmable  
Total Power ----- 36 Watts max  
Input voltages ----- 5 ~ 30 VDC



## Product Overview

The BUCKxx LED Power Modules are a line of true current regulated drivers for powering LEDs. The BUCKxx line of LED drivers are the ideal choice for powering all types of high-brightness and high-power LED Packages and LED arrays.

The line of BUCKxx LED drivers exhibit high efficiency and require no external current limiting resistors or additional heat sinking for operation. A fast response current-sensing circuit makes the BUCKxx ideal for applications where flashing or strobe operation of the LED(s) is required.

A wide range of options are available including DC input, TTL/CMOS logic level on/off control.



## Features

- n DC input power up to 30V
- n 350mA ,700mA ,1.0A ,1.2A ,1.5A ,2.0A constant current output
- n Extremely small form factor
- n Simple connection for through-hole PCB mounting or use with optional wiring harness
- n External digital intensity control (TTL compatible)
- n Output short circuit protection
- n Output open circuit protection
- n Pulse and strobe capable (DIM input)

## Typical Applications

- n Solar & Landscape Lighting
- n Architectural Lighting
- n Track Lighting
- n Automotive & Marine Lighting
- n Portable Lighting & Flashlights
- n Point of purchase Lighting
- n Desk & Reading Lamps
- n Signal & marker Lighting
- n Flashing & Strobe Lighting
- n Cabinet & Display Case Lighting
- n Sign & Channel Letters
- n Much More .....

## ENVIRONMENTAL

- n Operating temperature ----- - 40°C to + 65°C
- n Storage temperature ----- - 40°C to + 85°C
- n Humidity (Non - Condensing) ----- 5% to 95%
- n Cooling ----- Convention
- n Vibration Frequency ----- 5 to 50 HZ
- n MTBF ----- >100,000 Hours at full load and 25°C ambient conditions (MIL-217F)



CEETUS ENTERPRISE CORPORATION

希得股份有限公司

# DC DRIVER BUCKXX-DM SERIES

## Absolute Maximum Ratings

Input voltage -----	30VDC
Output Voltage -----	30VDC
DIM Pin Voltage -----	10VDC

## Typical Characteristics

Output tolerance (within specified temp. range) -----	± 7.5%
Efficiency -----	95%
Input Voltage Minimum -----	5VDC
Input Margin (add to LED Vf max) -----	0.8VDC

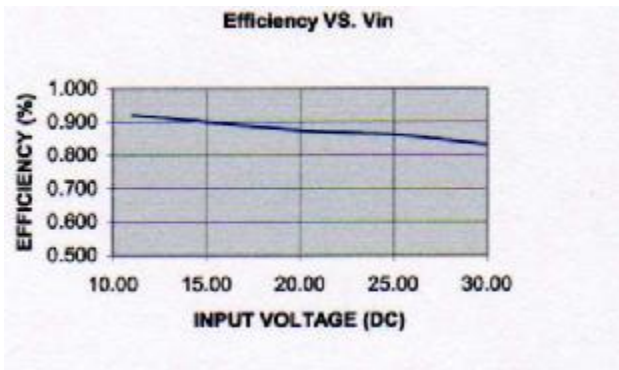

Figure 1.

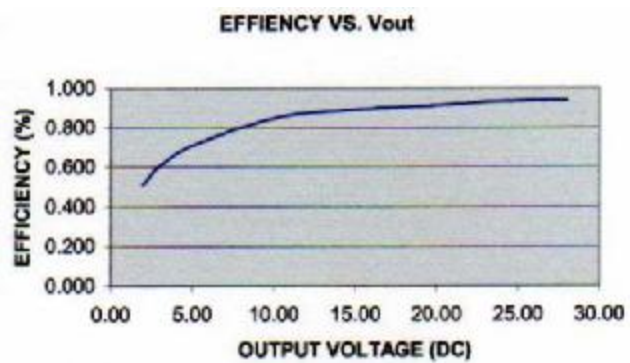

Figure 2.

## Application Information

### Description

The BUCKxx Wide Range LED Power Module is a high efficiency dc to dc converter which delivers a fixed output current by varying the output voltage as required to maintain the specified current. A fast response current-sensing circuit permits the unit to be used in applications where flashing or pulsing of the LEDs is required. Several options are available allowing for use with many types of LEDs and in a variety of operating modes

### Fixed Current Drive

The fixed output versions of the BUCKxx are designed to supply their rated current to one or more LED junctions. Due to the nature of the buck regulator, the input voltage must always be higher than the total forward voltage drop of the LED junction(s)

Figures 3 through 6 show 700 mA and 1000 mA rated units driving multiple LEDs. Note that parallel strings of LEDs can be driven directly with no additional circuitry required to insure current sharing. The nature of the LEDs themselves will provide good current sharing if the parallel strings comprise 3 or more junctions each.



# DC DRIVER BUCKXX-DM SERIES

## External Pulse /Strobe Control

Figures 9 show a method for low speed pulsing or high speed flashing operation. And a TTL/CMOS logic signal is applied directly to the dimmer(DIM) input of the BUCKxx. The output current will be zero when the control signal is high. Note that the input needs to source a minimum of 4.75VDC into a 1K ohm input impedance. Also, as is the case with a dc control signal, the logic input ground should to be common to GND.

## Microprocessor Control

Figure 10 shows a typical interface for a microchip PIC or similar  $\mu$  controller.

## Connections

The power input wires/traces should also be kept short. Where DC input units are located more than 18" from the source, a 220  $\mu$ F, 50V capacitor should be placed across the input terminals as shown in Figure 11.

## Application Figures

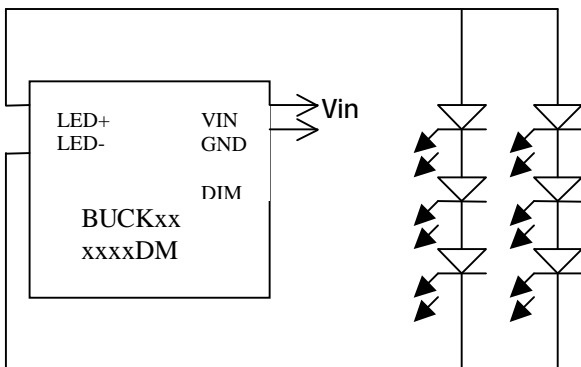

Figure 3.

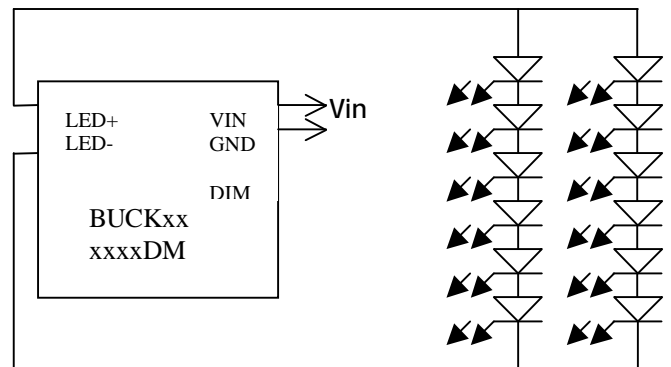

Figure 4.

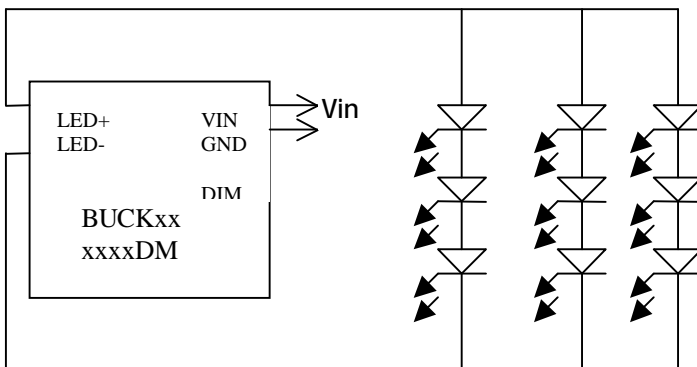

Figure 5.

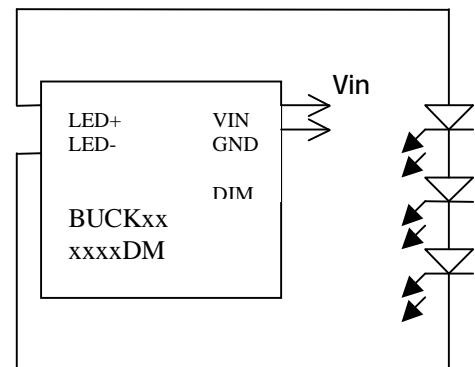

Figure 6.



CEETUS ENTERPRISE CORPORATION

希得股份有限公司

# DC DRIVER BUCKXX-DM SERIES

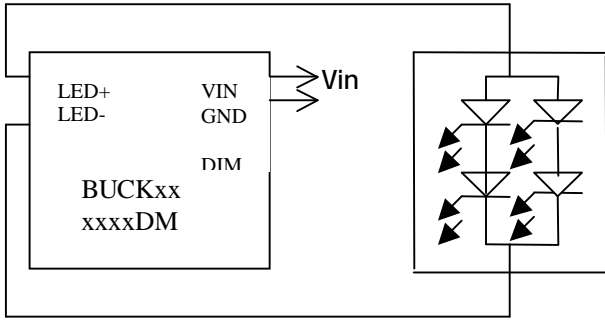

Figure 7.

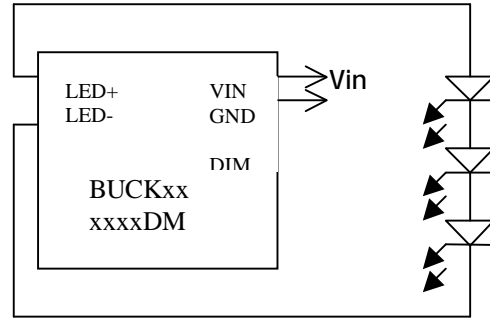

Figure 8.

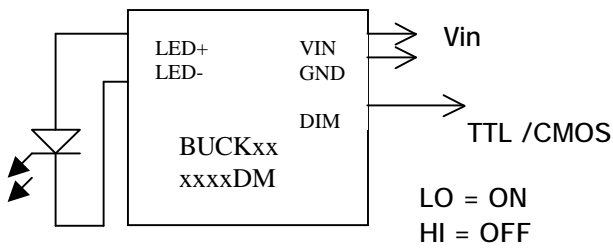

Figure 9.  
Pulse / Strobe input 5V = OFF

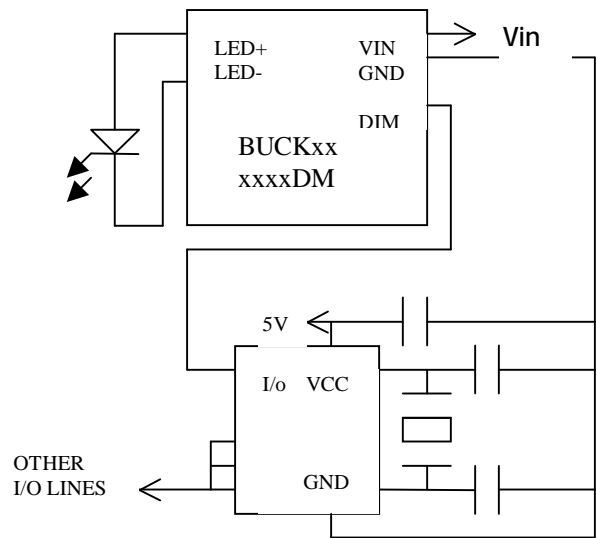

Figure 10.  
Interface to PIC or other microcontroller

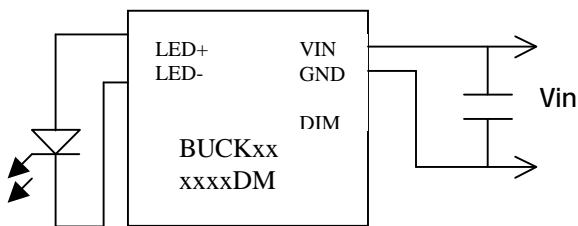

Figure 11.

Place a capacitor across the input terminals when the distance to the DC power source is greater than 18 inches

For more details of the layout ref., please contact [sales@ceetus.com.cn](mailto:sales@ceetus.com.cn) for inquiry.